

OPERATING INSTRUCTIONS

KODIAK

CR30



082017 Translation of the original user manual

GB

ORDER NO.: 00513

082017

A/S Wodschow & Co.

Kirkebjerg Søpark 6
DK-2605 Brøndby

Phone: +45 43 44 22 88
www.bearvarimixer.com
info@wodschow.dk

Denmark

CONTENTS:

GENERAL:	2
UNPACKING:	2
TRANSPORT:	3
INSTALLATION AND FIXING:	3
COMMISSIONING:	4
RECOMMENDED USE OF THE MACHINE:	4
TECHNICAL DATA:	4
MAX. CAPACITY OF THE MACHINE:	4
COMPONENTS OF THE MACHINE:	5
SAFETY:	6
ADJUSTMENTS:	6
KODIAK USER-FRIENDLINESS:	7
OPERATING THE MIXER:	8
OVERLOADING:	9
PROCEDURE IN CASE OF OVERLOADING:	9
RECOMMENDED MAX. SPEEDS:	9
RECOMMENDED MAX. SPEEDS FOR ATTACHMENT DRIVE:	9
CORRECT USE OF TOOLS:	9
CLEANING:	9
LUBRICATION AND GREASE TYPES:	9
ATTACHMENT DRIVE:	9
SYSTEMATIC MAINTENANCE:	10
DISPLAY OF MIXER DATA	10
ERROR CODES AND POSSIBLE SOLUTIONS:	11
ACCESS TO THE FUSE:	11
CIRCUIT DIAGRAM:	12
EXAMPLE ELECTRICAL CONNECTIONS:	13

GENERAL:

This manual should be seen as an integral part of the mixer and should be kept by the machine throughout its working life.

Before the machine is commissioned, it is important to read these instructions thoroughly, particularly the section on user safety.

The manufacturer may update the product manual without updating this copy of the manual.

The manufacturer will not be liable for faults caused by:

- Careless, improper or incorrect use of the mixer
- Non-standard use (not for the purposes described in the manual)
- Incorrect installation
- Incorrect power supply to the machine
- Failure to comply with maintenance instructions
- Modifications to the machine
- Spare parts and accessories that are not original or specified for this model
- Failure to comply with instructions in this manual

In case of faults with the mixer, please contact the supplier.

The guarantee does not cover damage caused by misuse, overloading or the user's failure to comply with the maintenance instructions.

UNPACKING:

The machine should be unpacked and the packaging disposed of according to regulations applicable in the country concerned.

Before the mixer is removed from the pallet, check that all parts are present with the machine:

- Safety guard
- Power cable
- 32 mm fixed spanner for legs.
- Fittings for fixing the machine to the floor
- Bowl trolley and bowl
- Whip, beater, hook and scraper with blade, if these were selected with the order.

The machine can be released from the pallet by cutting the strips.

TRANSPORT:



Lifting equipment should always be used to move the machine. Allowance should be made for the fact that the machine is 'top-heavy'.

The machine must not be pulled or lifted by the bowl lift handle.

When the machine is moved, it should be in a vertical position at all times.

INSTALLATION AND FIXING:

The ambient temperature around the machine must not exceed 45°C.



When the mixer is delivered, the adjustable feet will be turned right to the bottom. **The height of the legs should be adjusted** so that the bowl on the bowl trolley fits perfectly into the bowl arms.

The bowl arms should be at the correct height above the floor before the machine is taken into use – see **Adjustments, page 6**.

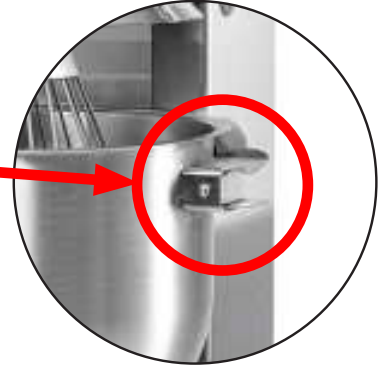

The legs of the mixer are adjustable and can be adjusted by turning them individually. See **Adjustments, page 6**.

The mixer is fixed in place using the fittings that come supplied:

- The mixer should be fixed to the floor if it is installed on board a ship.
- The mixer should be fixed to the floor if the hook tool is used at speeds above setting 3 (recommended maximum speed with hook).

Use M10 screws that are suitable for the floor material.

2 pieces washer M10

Tighten the M8 pointed screw after installation.

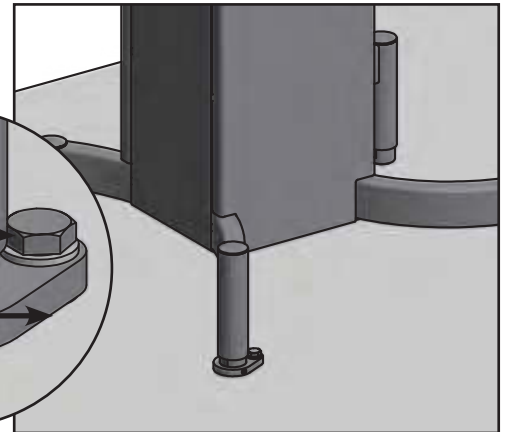
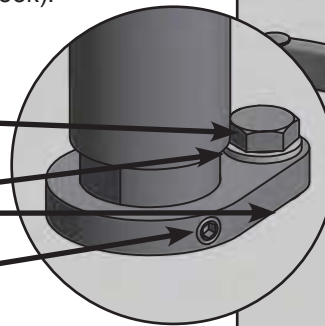

Electrical connection:

Users can connect the mixer to the power supply themselves; refer to the section on **Electrical connection** which must be followed.

For the benefit of service staff, it should be clear to see when the mains plug to the mixer has been removed from the socket in the wall.

The cable is fixed to the machine on the mains board with a wire loop.



Before the machine is connected to the mains, check that the voltage and frequency printed on the name plate are correct for the installation location. The name plate is positioned uppermost on the back of the machine.

There is a risk of injury if the machine is not earthed.

It must be ensured that the cable used to connect the machine to the mains meets the standard for the country in which the machine is installed. See also **Example electrical connections, page 13**

The mixer must be earthed. Failure to do so may cause injury. If there is no earth connection, the EMC filter will not work, with the risk of damage to the frequency converter.

When the machine is connected, **phase + neutral + earth** or **phase + phase + earth** should be used. In both cases, it is important to ensure that the voltage between the two live pins matches the name plate. (See **examples on page 13**)

The machine must only be connected to an earthed mains supply.

A plug with two pins plus earth should be used. Alternatively, two wires plus earth from a three-phase supply may be used.

The machine should be protected by a differential switch.

The machine is protected by a 10A fuse. The fuse is built into the socket on the back of the machine.

COMMISSIONING:

Bowl, tools and safety guard should be cleaned before use – see section on **Cleaning, page 9.**

The bowl arms should be at the correct height above the floor before the machine is taken into use – see **Adjustments, page 6.**

RECOMMENDED USE OF THE MACHINE:

The machine is designed for the manufacture of products that do not trigger any reactions or release substances that may be harmful to the user when in use.

The machine must not be used in an explosive atmosphere.

The mixer must only be operated by staff who have been trained in the use of the machine according to these instructions. Users must be over 14 years of age.

The mixer is designed for commercial use in kitchens, catering outlets and bakeries.

The machine may only be used as specified in this manual.

Only bowls designed for Kodiak may be used.

Tools should be used in conjunction with the corresponding bowl – a 30L tool with the 30L bowl and a 30/15L tool with the 30/15L bowl.

Unless the change is recommended by the manufacturer, modifying the machine is prohibited.

If the machine is fitted with an attachment drive, only accessories produced or recommended by A/S Wodschow & Co should be attached.

TECHNICAL DATA:

Gross weight	Net weight	kW	Volts	Amps	Variable speed, tool
145 kg	115 kg	1.2 kW	230V	10A	64 – 353 rpm

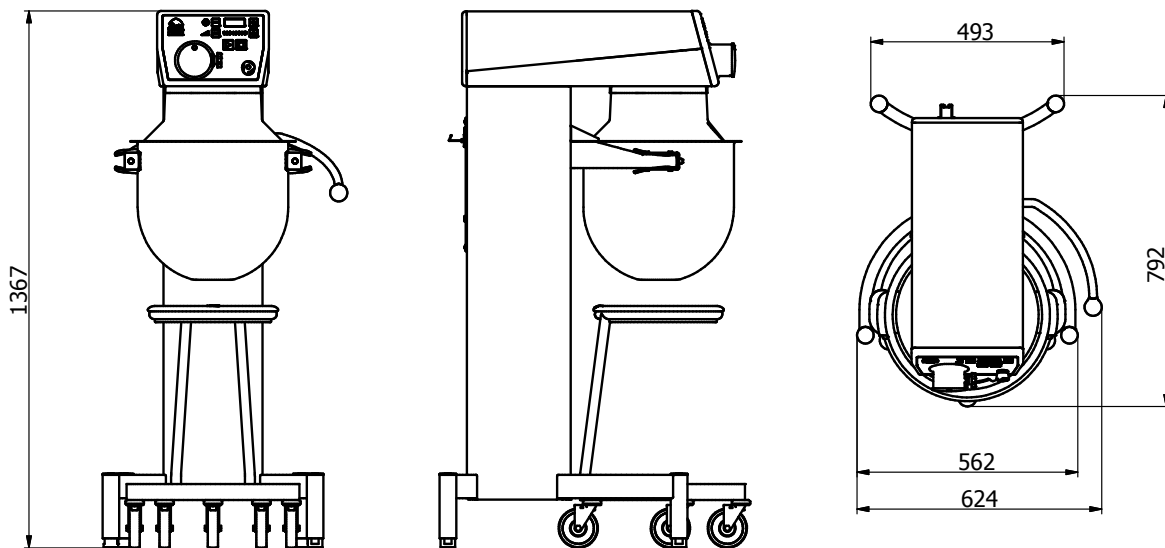
**MAX. CAPACITY OF THE MACHINE:**

Capacity per mix	Tool	KODIAK
Egg white	Whip	3.0 l
Mayonnaise	Whip	20 l
Yeast dough (60% AR)	Hook	13 kg
Meatball mix	Beater	20 kg

Local variations in the quality of the raw materials may affect water absorption, volume, baking characteristics etc., and hence capacity.

AR = absorption ratio (%AR)
(liquid as % of dry matter)

E.g. a basic recipe includes 1 kg dry matter and 0.6 kg liquid:

$$\text{this gives AR} = \frac{0.6 \text{ kg} \times 100}{1 \text{ kg}} = 60\%$$

If, for example, the maximum capacity of the mixer is required, the calculated AR = 60% is used to determine the amount of dry matter and liquid in the dough:

Maximum capacity of the machine = 13 kg for dough with AR = 60%
Now the weight of the dry matter in this dough is calculated as follows:

$$\text{Dry matter} = \frac{\text{max. capacity} \times 100}{\text{AR} + 100} = \frac{13 \text{ kg} \times 100}{60 + 100} = 8.125 \text{ kg}$$

$$\text{Weight of liquid} = 13 \text{ kg} - 8.125 \text{ kg} = 4.875 \text{ kg}$$

COMPONENTS OF THE MACHINE:**Standard equipment, as follows:**

- Bowl trolley
- Bowl – 30 l
- Hook, beater and whip for 30 l bowl

Optional accessories

- Scraper for 30 l bowl, if mixer is fitted for a scraper
- Bowl – 15 l
- Hook, beater and whip for 15 l bowl
- Scraper for 15 l bowl, if mixer is fitted for a scraper

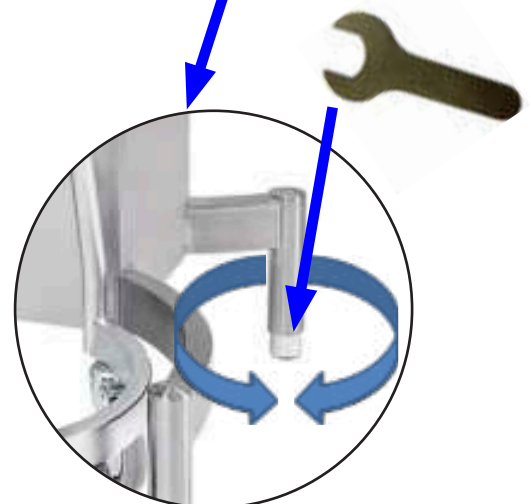

SAFETY:

The machine is designed for the manufacture of products that do not trigger any reactions or release substances that may be harmful to the user when in use.

Users must be over 14 years of age and trained in the use of the machine according to these instructions.

User safety is assured as follows:

- Tools can only rotate when the safety guard is in place and the bowl is lifted.
- The safety guard is made of plastic. It is not possible to attach the guard incorrectly.
- No access to rotating tools.
- The spread of flour dust is inhibited.
- Equipped with emergency stop - The tool stops rotating in less than 4 seconds (also for normal shut-down and stop via safety guard).
- Clearance between guard/stand and lifting handle at least 50 mm.
- Noise level under 70 dB.
- Machine remains stable on a slope of up to 10°. The distance from the floor to the bowl arm should be adjusted as shown in the section on **Adjustments, page 6**.

The machine is protected against overvoltage.

Non-ionising radiation is not produced intentionally, but rather technically conditioned by electrical equipment (e.g. electric motors, live power lines or solenoids). The machine is not equipped with strong permanent magnets. By maintaining a safe distance (between the field source and implant) of 30 cm, any impact on active implants (e.g. pacemakers, defibrillators) can likely be prevented.

The machine should be positioned to allow space for normal use and maintenance.

Good ergonomics for the user is ensured by the accompanying bowl trolley, which eliminates heavy lifting of the bowl and maintains the right working height.

The following recommendations apply to work with powdery ingredients:

- Powdery ingredients should not be poured into the bowl from a great height.
- Bags of e.g. flour should be opened at the bottom, down in the bowl.
- Do not run up to the maximum speed too quickly.



There is a risk of injury if the machine is not earthed.

It must be ensured that the cable used to connect the machine to the mains meets the standard for the country in which the machine is installed. See also '**Electrical Connection**'.

Placing your hands in the bowl while the machine is running may cause physical injury.

ADJUSTMENTS:

When the mixer is delivered, the adjustable feet will be turned right to the bottom. **The height of the legs should be adjusted** so that the bowl on the bowl trolley fits perfectly into the bowl arms.



To lower leg = turn anticlockwise

To raise leg = turn clockwise



If the floor is not level, the legs can be adjusted individually to ensure that installation is correct.

Together with the mixer comes a 32 mm fixed spanner to be used for adjustments.



KODIAK USER-FRIENDLINESS:

KODIAK has designed in partnership with kitchen and bakery staff, which has resulted in a number of user benefits:

The machine itself

Can be connected to the mains by the user

Is made of stainless steel

Has height-adjustable feet to ensure that the high bowl trolley works properly

Is easy to clean, with large surfaces and a removable safety guard which can be machine-washed

Power cable held with a loop so it cannot be shaken loose from the machine

The inclined control panel combined with the large bowl diameter provides a good view of the contents of the bowl.

Control panel:

The control panel is simple and intuitive, with large push buttons.

The speed can be increased/decreased continuously by holding down **+** and **-**. It is also possible to 'step' between the predefined speeds 12345678.

The panel is inclined at the ergonomically correct height, making it very comfortable to use.

The panel is easy to clean with a damp cloth.

There is a built-in timer function with a display, which can also be used to show the number of operating hours.

Safety guard:

The one-piece safety guard is made of transparent plastic. The guard is easy to remove and clean. The guard can be machine-washed at up to 60° and can withstand up to 90° for short periods.

The guard is made of a special impact-resistant material which can withstand daily use in a commercial kitchen.

The safety guard is held in place by magnets, so there are no loose parts that can break or collect dirt.

It is not possible to attach the guard incorrectly.

A force corresponding to 3 kg or 30 N should be used to remove the guard.

The filling hole in the safety guard can be turned to suit the user's needs.

Bowl and bowl trolley:

The bowl is not very deep but has a large diameter, which makes it easier to see the contents while working.

The bowl does not have to be lifted into place in the bowl arms, but can be wheeled directly into position.

The bowl trolley is used for transfer from mixer to workbench, dishwasher, stores etc.

The bowl trolley provides an ergonomically correct working height.

The bowl trolley spares the user any heavy lifting.

The bowl can be tilted in the rubber ring on the bowl trolley.

Tools:

The mixer whip is very compact in design, which provides for a long service life. It must be handled according to these instructions.

The beater and hook are made of stainless steel.



OPERATING THE MIXER:

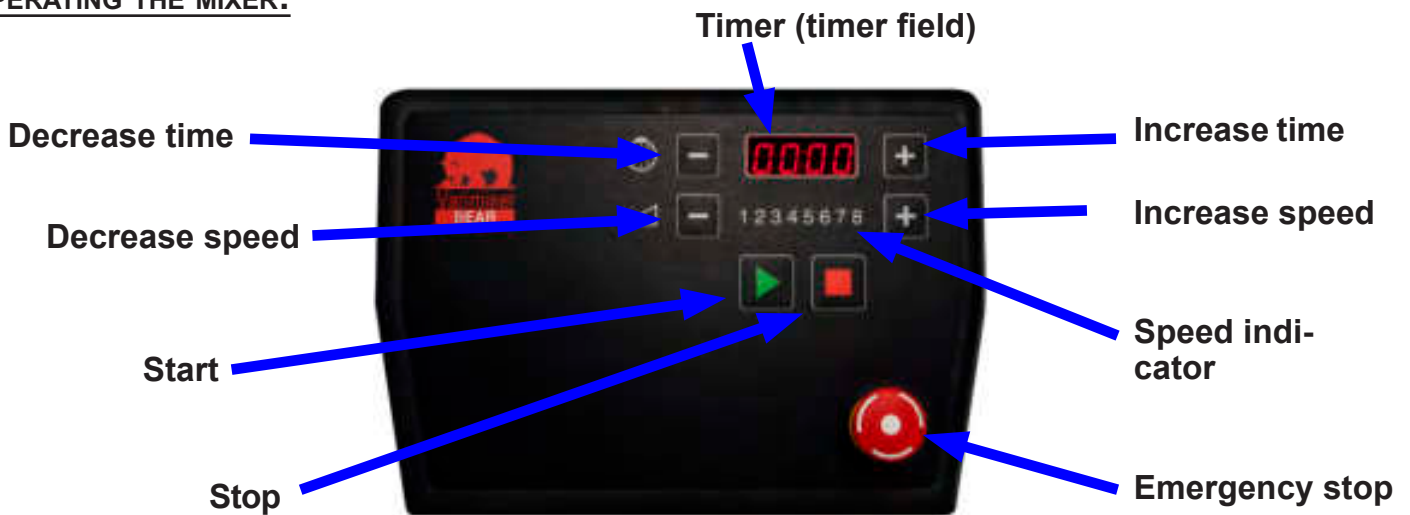

Before starting the machine:

Place the bowl in the bowl trolley.

Put the desired tool into the bowl and wheel it into position between the bowl arms. Ensure that the bowl is correctly engaged with the bowl arms; see **Adjustments, page 6**.

Fit the safety guard and turn it so the filling hole is accessible when the machine is running.

Turn the tool to lock it into the bayonet fitting.

Lift the bowl with the aid of the lifting handle.

The mixer is now ready to start.

It is possible to set both the running time and speed before starting the machine; see next section:

Start the machine:

Press to start the mixer.

Press next to to increase the speed.

Press next to to reduce the speed.

The speed is shown as a number on the scale 12345678.

The display **1**2345678 represents the lowest speed, approx. 64 rpm.

The display **12345678** represents the highest speed, approx. 353 rpm.

Display of running time – hours:

Select a running time for the mixer by pressing next to . The running time is shown in minutes and seconds in the timer field between and .

Running times of up to 90 minutes are available.

The running time will not be reset if is pressed once; press once more and it will be reset.

If no running time is selected, the display will show the time elapsed since the mixer was started.

Inspection of ingredients while in use:

If the mixer needs to be stopped temporarily without affecting the running time, press . The mixer will slow down and then stop and the running time will stop too.

The bowl can now be lowered and the ingredients checked.

Lift the bowl and press , and the mixer will start and the running time will resume.

Stop the machine:

To stop the machine:

- Press . Running time not reset.
- Press twice. Running time reset.
- Press the emergency stop - the running time will be reset.
- 'Tilt' the safety guard - the running time will be reset.
- Lower the bowl - the running time will be reset.

In all cases the mixer can be restarted by pressing .

It will start at the lowest speed.

Resetting the timer:

The timer can be reset by pressing and next to at the same time. If the timer is reset while the mixer is running, the machine will stop and beep.

OVERLOADING:



The mixer must not be overloaded.

Possible overload situations:

- Working with excessively tough and heavy dough
- Mixer tool exceeding the recommended speed
- Wrong mixer tool being used.

Larger lumps of fat or chilled ingredients must be reduced before they are placed in the bowl.

Prolonged overloading will cause the frequency converter to stop the machine.

OL: will be displayed in the timer field; the speed will not be reduced, but the mixer will stop and the display will change to **EE: 7**. Follow the description under **Procedure in case of overloading**.

PROCEDURE IN CASE OF OVERLOADING:

Remove the cause of the overloading, e.g. empty the bowl.

To remove the display, **EE: 7** press .

The mixer can now be restarted.

RECOMMENDED MAX. SPEEDS:

- The mixer should be fixed to the floor if the hook tool is used at speeds above setting 3 (recommended maximum speed with hook).

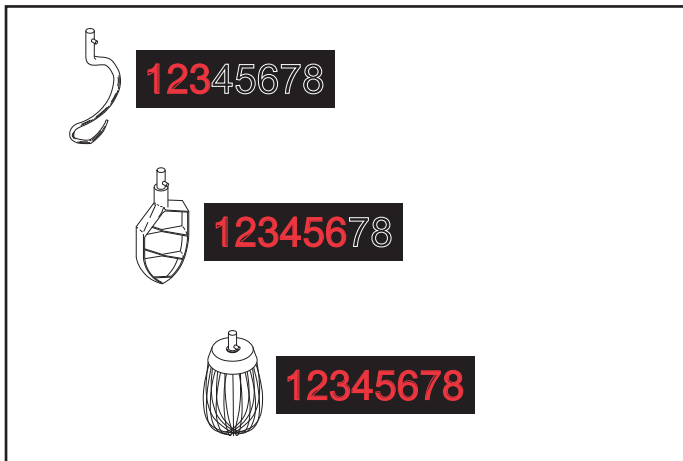

RECOMMENDED MAX. SPEEDS FOR ATTACHMENT DRIVE:

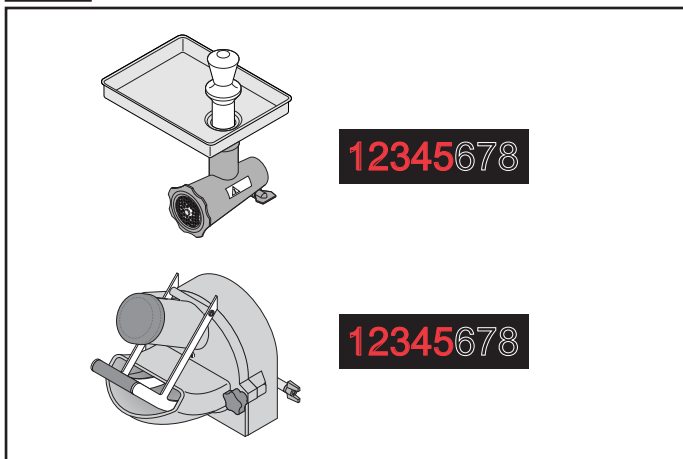

CORRECT USE OF TOOLS:

Recommended uses of tool:

Whip	Beater	Hook
Cream	Cake mix	Bread dough
Egg whites	Buttercream	Rye bread
Mayonnaise	Waffle mix	etc.
etc.	Forcemeat	
	etc.	



The whip should not be struck against hard objects such as the edge of the bowl. This will shorten the life of the tool because of increasing deformation.

To make mashed potato, use the beater and then the standard whip.

CLEANING:



The machine may only be cleaned by trained staff over 14 years of age.

The machine should be cleaned daily after use. It should be wiped with a soft brush and clean water. Sulphonated soaps should be used with care, as they destroy the lubricants in the machine.



The machine should never be rinsed with a hose.

Aluminium parts should not be used for strongly acidic, alkaline or saline food products, which may attack non-coated aluminium.

Aluminium mixer tools must not be washed in strongly alkaline agents (**pH between 5.0 and 8.0**).

Please note that the plastic safety guard may be damaged if it is exposed to high temperatures for a prolonged period. (**Max. temperature 60°C**)

The soap suppliers may be able to help by recommending the right type of soap.

LUBRICATION AND GREASE TYPES:



Lubrication and other servicing may only be carried out by trained staff over 14 years of age.

The lid of the mixer may only be removed when the cable to the mains supply has been removed.

When repairs are made to the mixer head, the gearwheel and internal gear should be lubricated with **Statoil GreaseWay ALX 42**, but the needle bearings in the mixer head should not be lubricated with this type of grease.

If the machine is supplied with an attachment drive, the gear for the attachment drive should be lubricated with **Statoil GreaseWay LiCa 80**.

Do not use any other grease types than those specified above.

ATTACHMENT DRIVE:

The machine may be fitted with an attachment drive into which optional accessories, such as meat mincers and vegetable cutters, can be attached.

For further information on the assembly and use of optional accessories, please refer to the manual that comes with the accessory.







The machine must be shut down when the accessory is fitted to the attachment drive.

SYSTEMATIC MAINTENANCE:



Part	Action	Frequency	Note
Safety guard	Check the safety of the safety guard: Does the tool stop rotating when the guard is tilted/removed?	Regularly	If the tool does not immediately stop rotating on tilting/removal of the guard, the machine must not be used. Call the engineer
Emergency stop	Test the emergency stop: Does the tool stop rotating when the emergency stop is activated?	Regularly	If the tool does not immediately stop rotating on activation of the emergency stop, the machine must not be used. Call the engineer
Mixer head	The mixer head should only be lubricated on repair, see the section "Lubrication and grease types".	During repairs	
The machine's other moving parts	The moving parts that belong to the bowl's lifting mechanism all run in maintenance-free plain bearings and should not therefore be lubricated.	Never	
Attachment drive	The rubber plug for covering the opening of the attachment drive should be on the machine and be intact.	Daily	The rubber plug must cover the opening on the attachment drive when the latter is not in use.
Cleaning	Follow the instructions in the section "Cleaning"	Follow the instructions in the section "Cleaning"	

DISPLAY OF MIXER DATA**Number of mains connections and control panel and frequency converter software version:**







- When the machine is connected to the mains, three values will be displayed in the text field on the panel:
- Number of times the machine has been connected, e.g.  for three times
- Control panel software version; first  is displayed, then the version, e.g.  for version 26
- Frequency converter software version; first  is displayed, then the version, e.g.  for version 18

Running time and error log

It is possible to display the time the machine has been on (the motor has been running):

- Hit emergency stop and press  next to .
- Time displayed in hours: 0 - 1 - 2 etc.
- Deactivate emergency stop to cancel the display.

It is possible to display a log of the errors that have occurred:

- Hit emergency stop and press  next to .
- The display shows the latest error first.
- To scroll back through the errors, press  next to ; to scroll forward, press  next to .
- The last eight errors can be displayed.
- Deactivate emergency stop to cancel the display.

ERROR CODES AND POSSIBLE SOLUTIONS:

For some errors, the control system will show an error code in the display:

EE: 1 User pressed  without raising the bowl to working height.

Solution: Raise bowl to working height.

EE: 2 User pressed  without fitting the safety guard.

Solution: Fit the safety guard.

EE: 4 The Thermal sensor in the motor has overheated.

Solution: The error will disappear when the temperature has dropped to an acceptable level.

Stop the mixer and reduce the quantity of ingredients in the bowl. When it starts again, select a lower speed.

EE: 6 There is an error in communication between the control panel and the frequency converter.

Solution: Call the engineer.

EE: 7 Error in frequency converter.

Solution: Call the engineer.

EE: 8 Thermal sensor in the frequency converter has cut out.

Solution: The error will disappear when the temperature has dropped to an acceptable level.

EE: 9 Intermittent low voltage in the power supply.

Solution: The power supply to the mixer should be checked by an expert.

EE: 10 Intermittent high voltage in the power supply.

Solution: The power supply to the mixer should be checked by an expert.

OL: The mixer is overloaded because of excessively heavy dough etc.

Solution: Reduce the quantity in the bowl; the product may need to be reduced or thinned before the machine is restarted. When it starts again, select a lower speed.

ACCESS TO THE FUSE:

If the fuse burns out, it can be replaced without the aid of technical staff.

- The fuse is located in the socket on the back of the machine.
- Remember to remove the mains cable before changing the fuse.
- The fuse can be changed by pulling out the little 'drawer' (A) on top of the socket (B). If the fuse has gone, it can be replaced with the spare fuse (C).

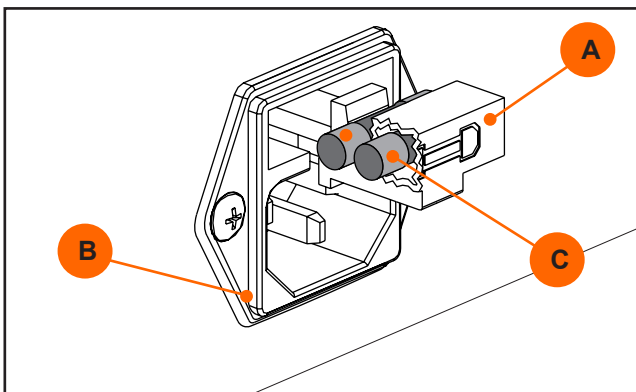

CIRCUIT DIAGRAM:

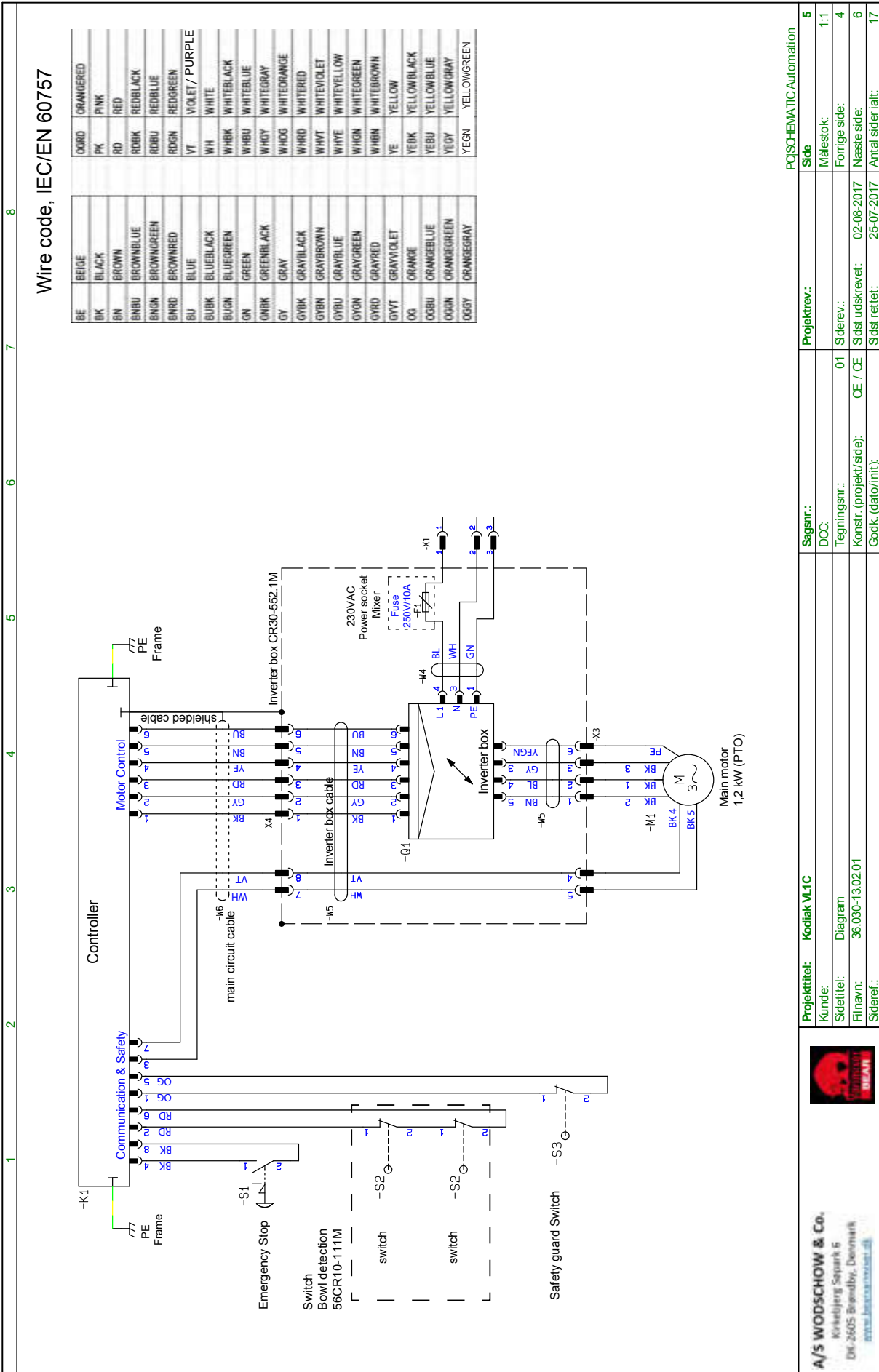

EXAMPLE ELECTRICAL CONNECTIONS:

Local 50/60 Hz supply.			Name plate				Notes
Power supply: phases x voltage	With neutral	Earth	Voltage	Phas- es	Use neutral	Use earth	
1 x 220-240V	Neutral	yes	230V	1	yes	yes	<p>Note that the machine must not be connected without an earth, as this may compromise the action of the EMC filter by removing the discharge to the ground, and may be dangerous for the user.</p> <p> For functional and safety reasons, the machine <u>must</u> be connected to the earth.</p>
2 or 3 x 220-240V	-	yes	230V	2	-	yes	
2 or 3 x 380-415V	Neutral	yes	230V	1	yes	yes	
2 or 3 x 380-480V	-	yes	380-480V	2	-	yes	

<u>Indhold af Overensstemmelseserklæring,</u> (Maskindirektivet, 2006/42/EC, Bilag II, del A)	DK
<u>Contents of the Declaration of conformity for machinery,</u> (Machinery Directive 2006/42/EC, Annex II., sub. A)	GB
<u>Inhalt der Konformitätserklärung für Maschinen,</u> (Richtlinie 2006/42/EG, Anhang II, sub A)	DE
<u>Contenu de la Déclaration de conformité d'une machine,</u> (Directive Machine 2006/42/CE, Annexe II.A)	FR
<u>Inhoud van de verklaring van overeenstemming voor machines,</u> (Richtlijn 2006/42/EC, Bijlage II, onder A)	NL
<u>Contenido de la declaración de conformidad sobre máquinas,</u> (Directiva 2006/42/EC, Anexo II, sub A)	ES

Fabrikant; Manufacturer; Hersteller; Fabricant; Fabrikant; Fabricante: A/S Wodschow & Co.
 Adresse; Address; Adresse; Adresse; Adres; Dirección: Kirkebjerg Søpark 6, DK-2605 Brøndby, Denmark

Navn og adresse på den person, som er bemyndiget til at udarbejde teknisk dossier
 Name and address of the person authorised to compile the technical file
 Name und Anschrift der Person, die bevollmächtigt ist, die technischen Unterlagen zusammenzustellen
 Nom et adresse de la personne autorisée à constituer le dossier technique
 naam en adres van degene die gemachtigd is het technisch dossier samen te stellen
 nombre y dirección de la persona facultada para elaborar el expediente técnico

Navn; Name; Name; Nom; Naam; Nombre: Kim Jensen
 Adresse; Address; Adresse; Adresse; Adres; Dirección: Kirkebjerg Søpark 6, DK-2605 Brøndby, Denmark
 Sted, dato; Place, date; Ort, Datum; Lieu, date ; Plaats, datum ; Place, Fecha: Brøndby, 28-09-2016

Erklærer hermed at denne røremaskine
 Herewith we declare that this planetary mixer
 Erklärt hiermit, dass diese Rührmaschine
 Déclare que le batteur-mélangeur ci-dessous
 Verklaart hiermede dat Menger
 Declaramos que el producto batidora

- er i overensstemmelse med relevante bestemmelser i Maskindirektivet (Direktiv 2006/42/EC)
 is in conformity with the relevant provisions of the Machinery Directive (2006/42/EC)
 konform ist mit den Bestimmungen der EG-Maschinenrichtlinie (Direktiv 2006/42/EG)
 Satisfait à l'ensemble des dispositions pertinentes de la Directive Machines (2006/42/CE)
 voldoet aan de bepalingen van de Machinerichtlijn (Richtlijn 2006/42/EC)
 corresponde a las exigencias básicas de la Directiva sobre Máquinas (Directiva 2006/42/EC)
- er i overensstemmelse med følgende andre CE-direktiver
 is in conformity with the provisions of the following other EC-Directives
 konform ist mit den Bestimmungen folgender weiterer EG-Richtlinien
 Est conforme aux dispositions des Directives Européennes suivantes
 voldoet aan de bepalingen van de volgende andere EG-richtlijnen
 está en conformidad con las exigencias de las siguientes directivas de la CE

2014/30/EU ; 1935/2004 ; 10/2011

Endvidere erklæres det
 And furthermore, we declare that
 Und dass
 Et déclare par ailleurs que
 En dat
 Además declaramos que

- at de følgende (dele af) harmoniserede standarder, er blevet anvendt
 the following (parts/clauses of) European harmonised standards have been used
 folgende harmonisierte Normen (oder Teile/Klauseln hieraus) zur Anwendung gelangten
 Les (parties/articles des) normes européennes harmonisées suivantes ont été utilisées
 de volgende (onderdelen/bepalingen van) geharmoniseerde normen/nationale normen zijn toegepast
 las siguientes normas armonizadas y normas nacionales (o partes de ellas) fueron aplicadas

EN454:2014 ; EN60204-1:2006; EN12100-2011

EN61000-6-1:2007; EN61000-6-3:2007

Innehåll i örsäkran om maskinens överensstämmelse, (Maskindirektivet 2006/42/EG, bilaga 2, A)
Contenuto della dichiarazione di conformità per macchine, (Direttiva 2006/42/CE, Allegato II, parte A)
Sisukord masina vastavusdeklaratsioon, (Masinadirektiiv 2006/42/EÜ, lisa II, punkt A)
Treść Deklaracja zgodności dla maszyn, (Dyrektywa maszynowa 2006/42/WE, Załącznik II, pkt A)
Sisältö vaatimustenmukaisuusvakuutus koneesta, (Konedirektiivi 2006/42/EY, Liite II A)

SE
IT
EE
PL
FI

Tillverkare; Fabbricante; Tootja; Producent; Valmistaja:

A/S Wodschow & Co.

Adress; Indirizzo; Aadress; Adres; Osoite:

Kirkebjerg Søpark 6, DK-2605 Brøndby, Denmark

Namn och adress till den person som är behörig att ställa samman den tekniska dokumentationen:

Nome e indirizzo della persona autorizzata a costituire il fascicolo tecnico

Tehnilise kausta volitatud koostaja nimi ja aadress

Imię i nazwisko oraz adres osoby upoważnionej do przygotowania dokumentacji technicznej

Henkilön nimi ja osoite, joka on valtuutettu kokoamaan teknisen tiedoston

Namn; Nome e cognome; Nimi; Imię i nazwisko; Nimi:

Kim Jensen

Adress; Indirizzo; Aadress; Adres; Osoite:

Kirkebjerg Søpark 6, DK-2605 Brøndby, Denmark

Ort och datum; Luogo e data; Koht, kuupäev; Miejsce, data; Paikka, aika:

Brøndby, 28-09-2016

Försäkrar härmed att denna blandningsmaskin

Con la presente si dichiara che questo mixer planetaria

Deklareerime käesolevaga, et Planetaarmikseri

Niniejszym oświadczamy, że mikser planetarny

vakuuttaa, että tämä mikseri tyyppi

- överensstämmer med tillämpliga bestämmelser i maskindirektivet (2006/42/EG)
is è conforme alle disposizioni della Direttiva Macchine (Direttiva 2006/42/CE)
vastab kehtivatele masinadirektiivi (2006/42/EÜ) nõuetele
spełnia wymagania odpowiednich przepisów dyrektywy maszynowej (2006/42/WE)
on konedirektiivin (2006/42/EY) asiaankuuluvien säännösten mukainen
- överensstämmer med bestämmelser i följande andra EG-direktiv
è conforme alle disposizioni delle seguenti altre direttive CE
vastab järgmiste EÜ direktiivide nõuetele
spełnia wymagania przepisów innych dyrektyw WE
on seuraavien muiden EY-direktiivien säännösten mukainen

2014/30/EU; 1935/2004 ; 10/2011

Vi försäkrar dessutom att

e che

Lisaks ülaltoodule deklareerime, et

Ponadto oświadczamy, że

ja lisäksi vakuuttaa, että

- följande (delar/paragrafer av) europeiska harmoniserade standarder har använts
sono state applicate le seguenti (parti/clausole di) norme armonizzate
kasutatud on järgmisi Euroopa harmoniseeritud standardeid (või nende osi/nõudeid)
zastosowano następujące części/klauzule zharmonizowanych norm europejskich
seuraavia eurooppalaisia yhdenmukaistettuja standardeja (tai niiden osia/kohtia) on sovellettu

EN454:2014 ; EN60204-1:2006; EN12100-2011

EN61000-6-1:2007; EN61000-6-3:2007

DS/EN 1672-2 + A1:2009

